

72
73
74
75
76
77
78
79
80
81
82
83
84
85
86
87
88
89
90
91
92
93
94
95

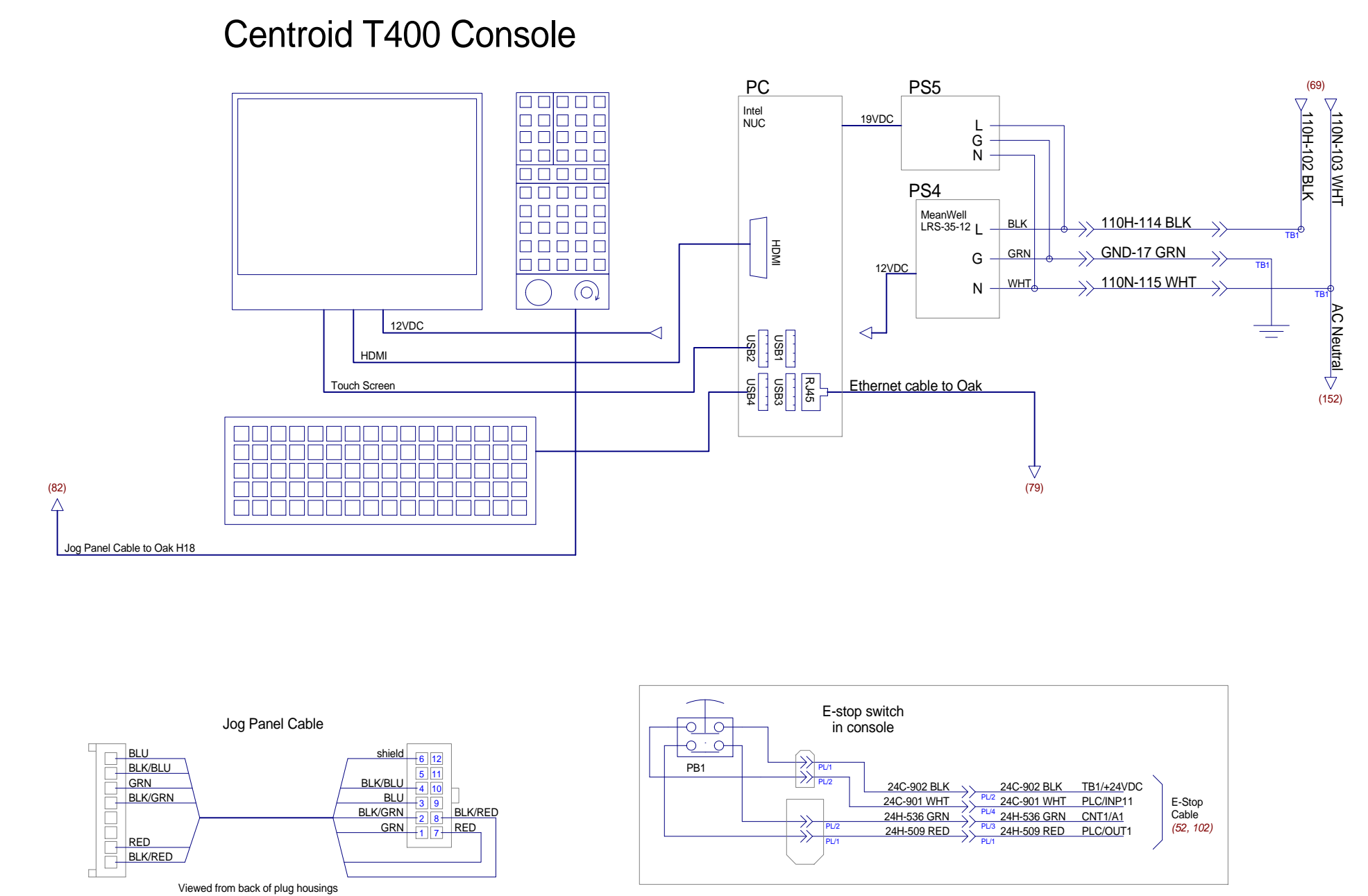

96
97
98
99
100
101
102
103
104
105
106
107
108
109
110
111
112
113
114
115
116
117
118
119

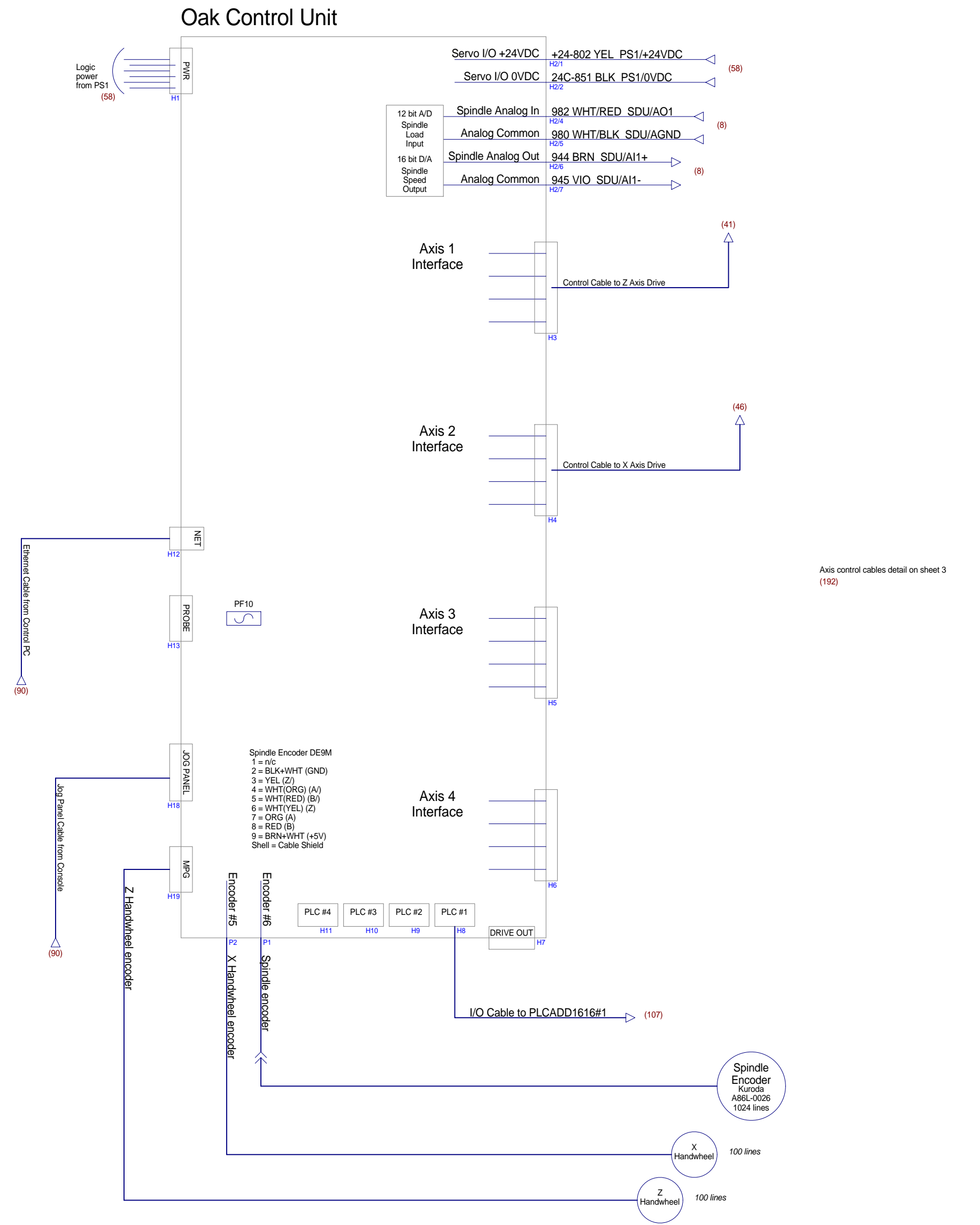
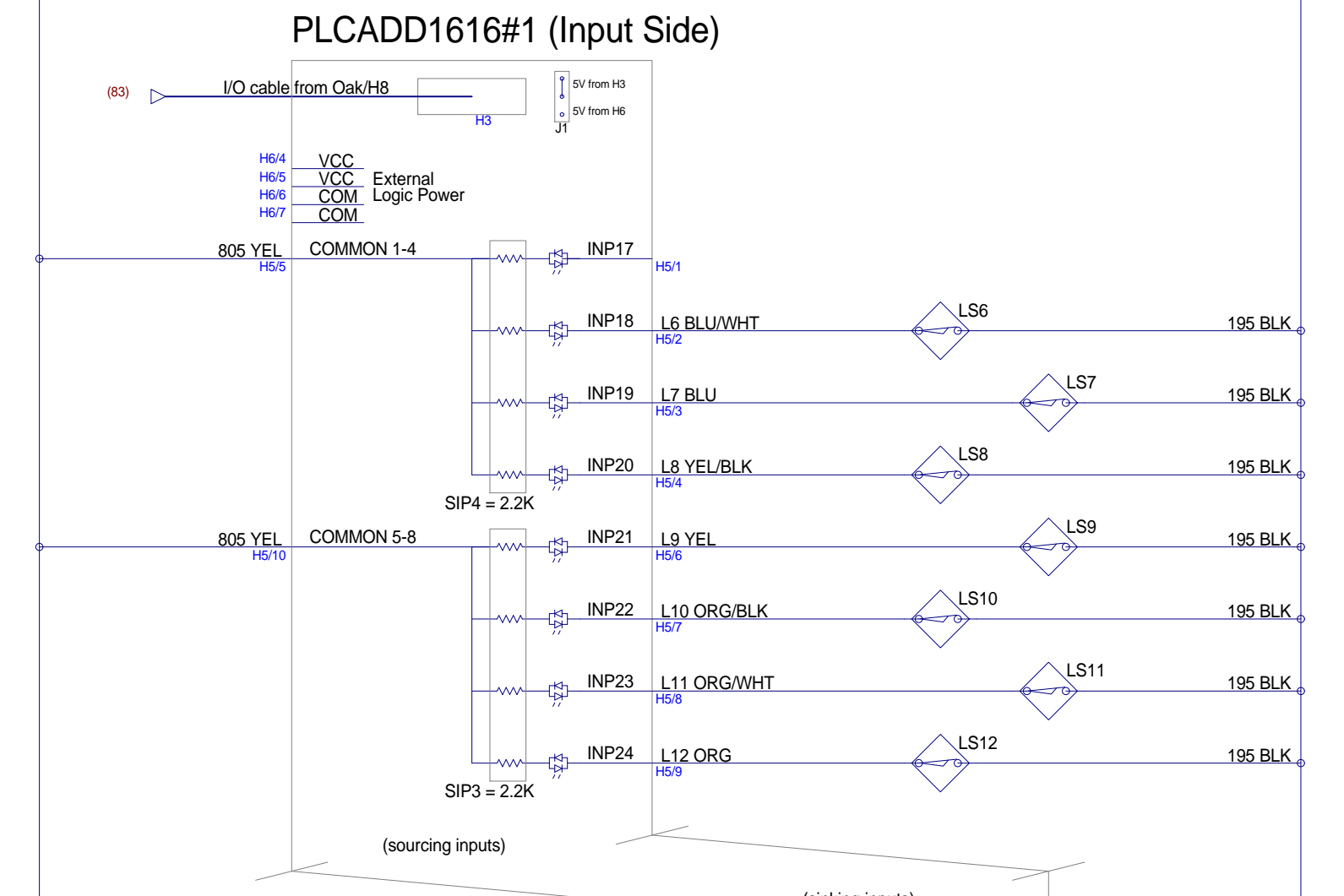
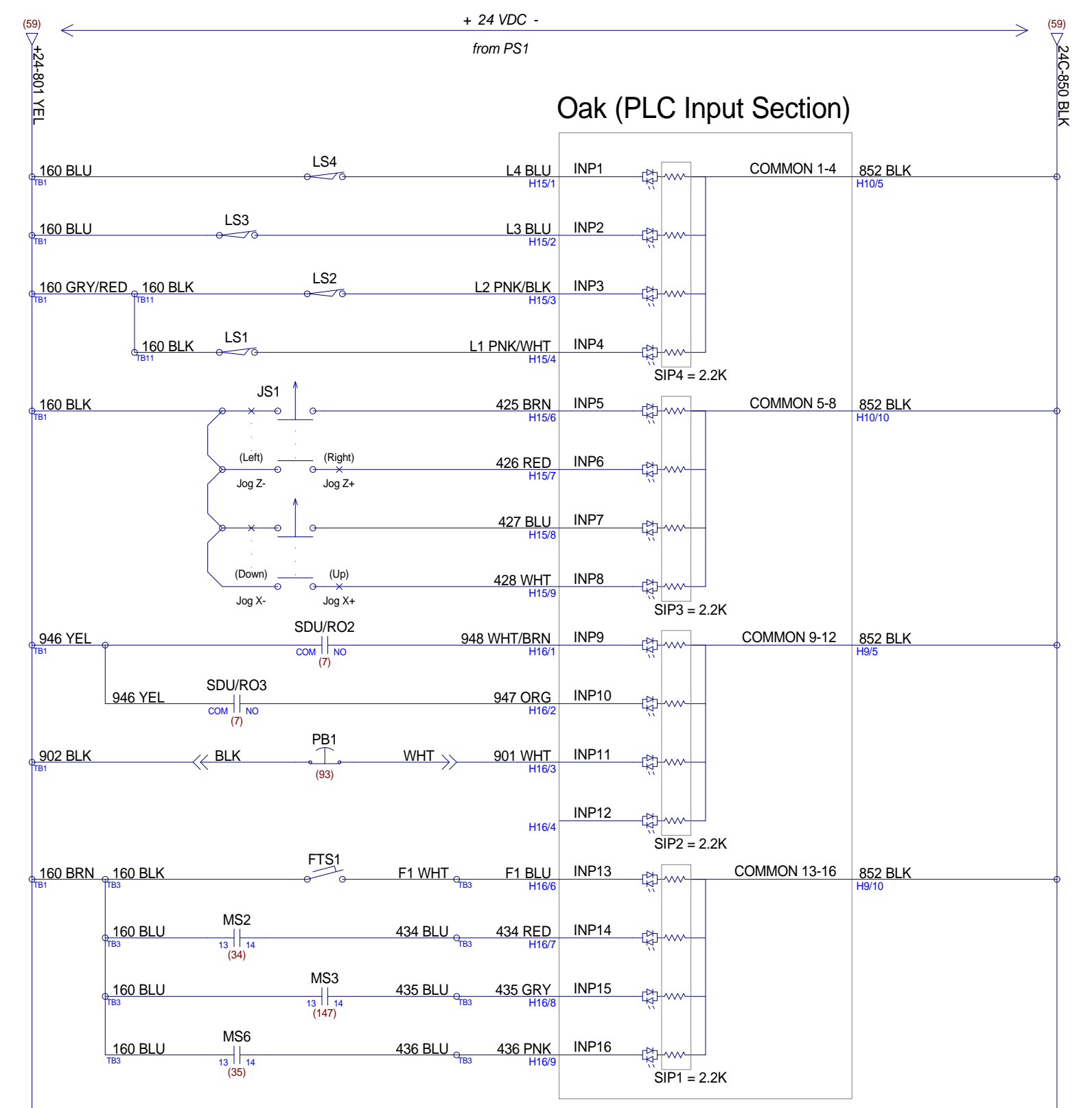

	A	B	C	D	E	F
L6 L7 L8 L9 L10 L11	0	1	1	1	1	1
T1	0	0	1	1	1	1
T2	1	0	0	1	1	1
T3	0	1	0	1	1	1
T4	1	0	1	0	1	1
T5	1	1	0	0	1	1
T6	0	1	1	0	1	1
T7	1	0	1	1	0	1
T8	1	1	0	1	0	1
T9	0	1	1	0	0	1
T10	1	0	1	1	1	0
T11	1	1	0	1	1	0
T12	0	1	1	1	1	0

0 = open = sensing
1 = closed = not sensing

(The limit sensors on this machine have been replaced with A.C. two-wire sensors, so the limit-positive truth table is inverted from the typical S6-series pattern)

120
121
122
123
124
125
126
127
128
129
130
131
132
133
134
135
136
137
138
139
140
141
142
143

