

Spindle Drive Unit (VFD)

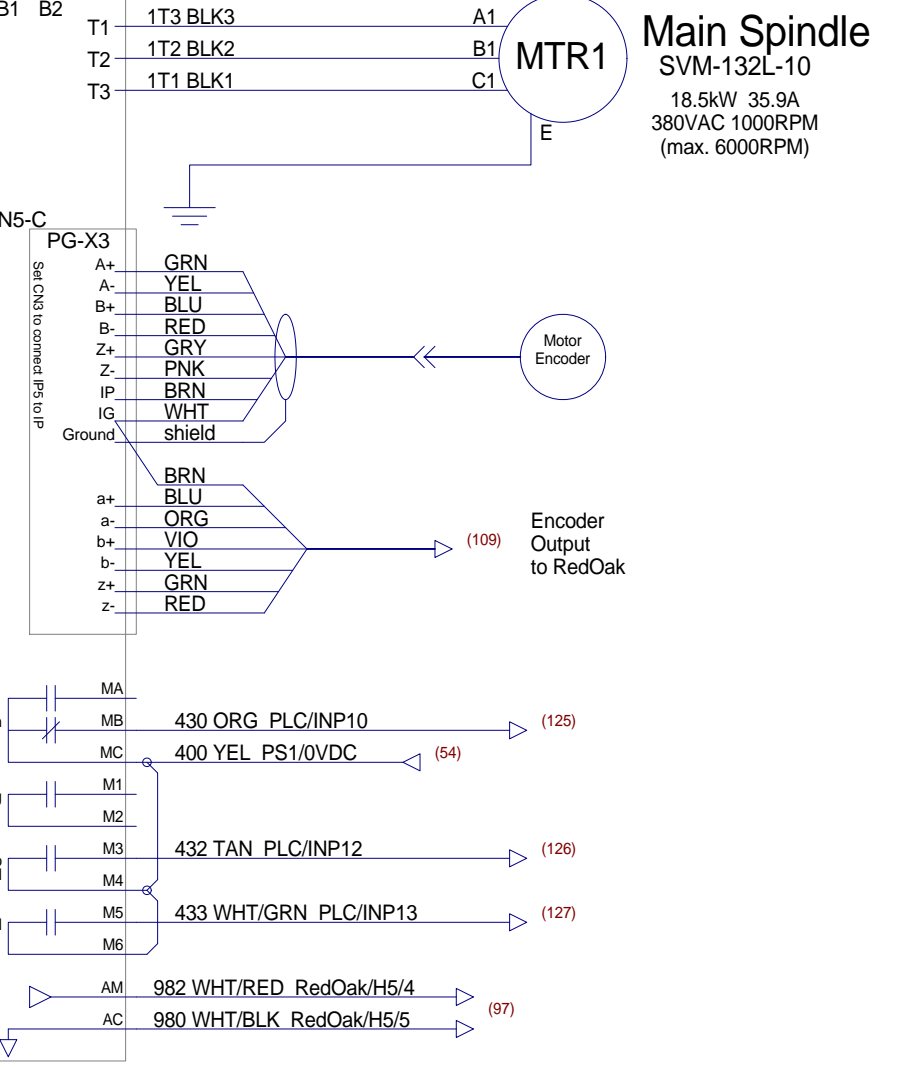

X Servo (SVX)

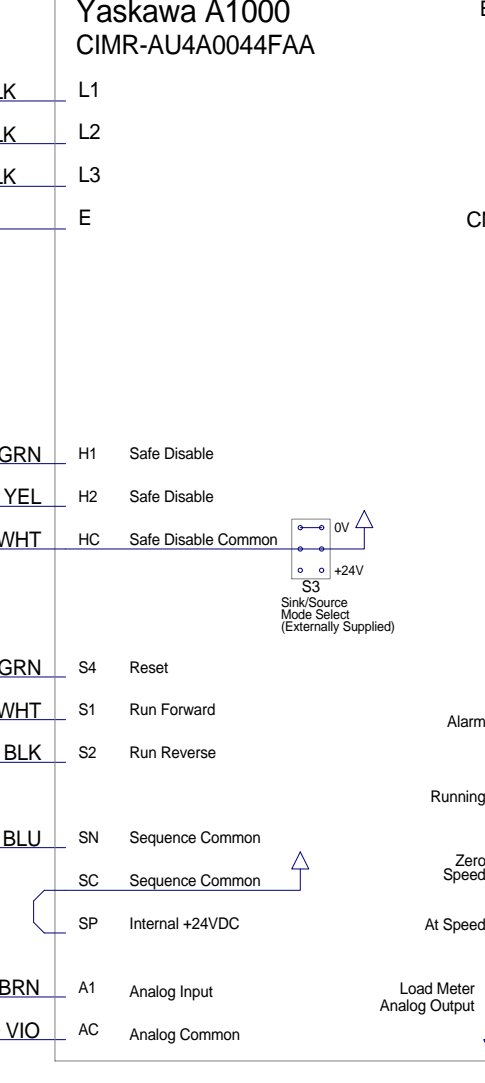
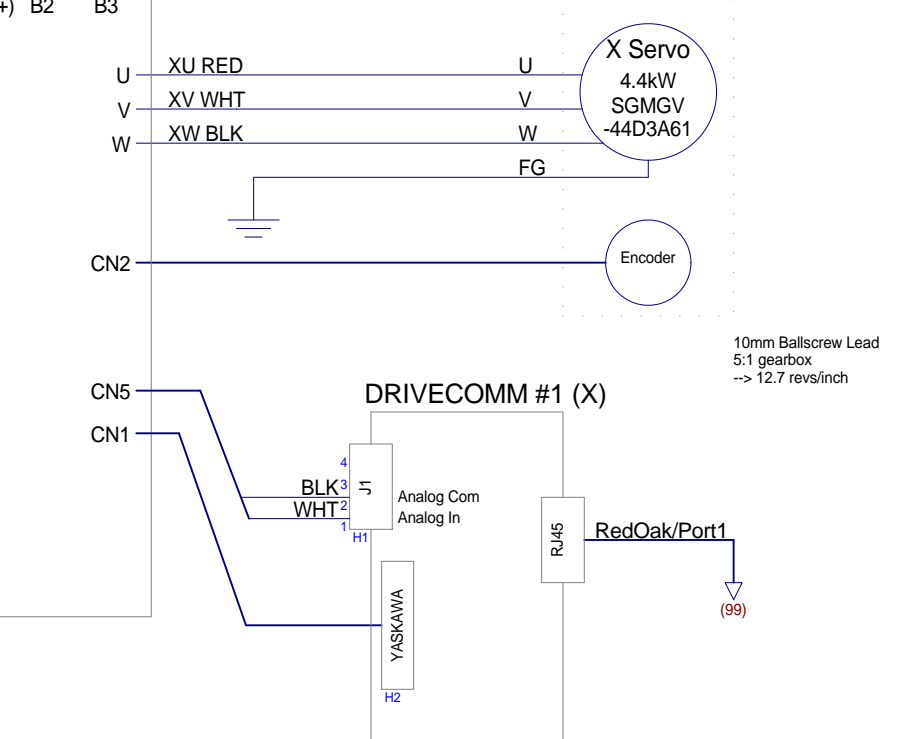
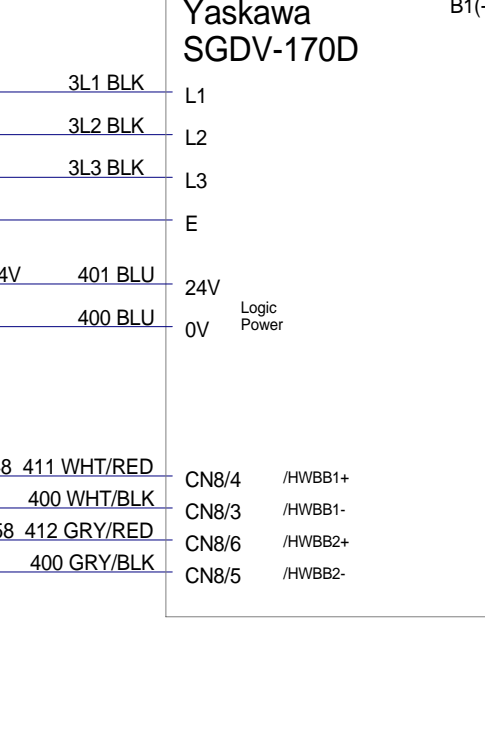

Y Servo (SVY)

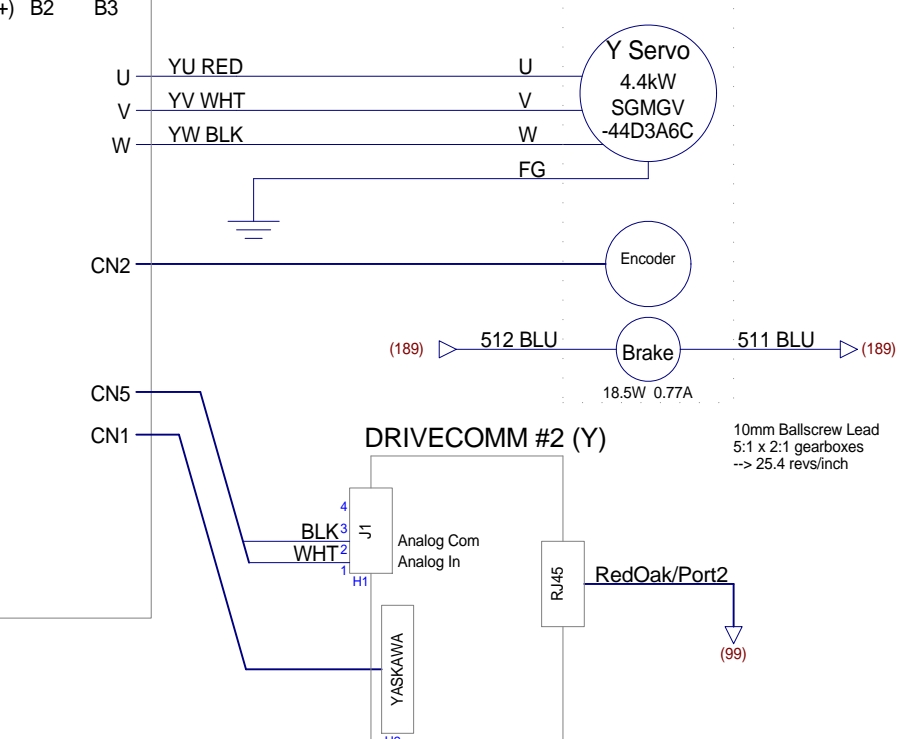
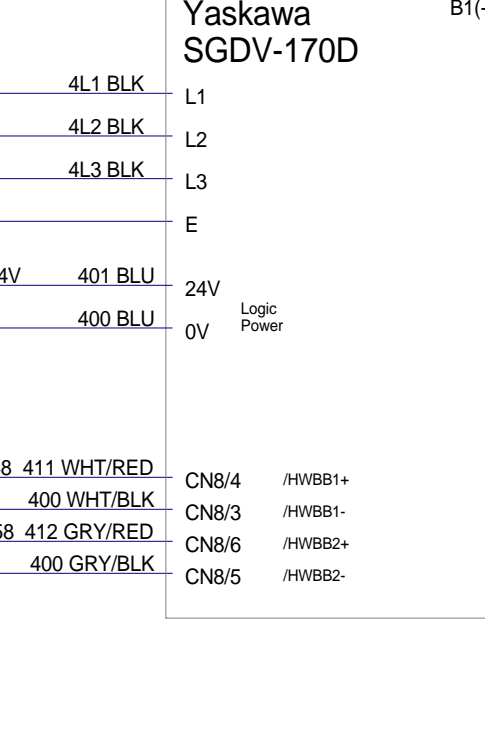

Z Servo (SVZ)

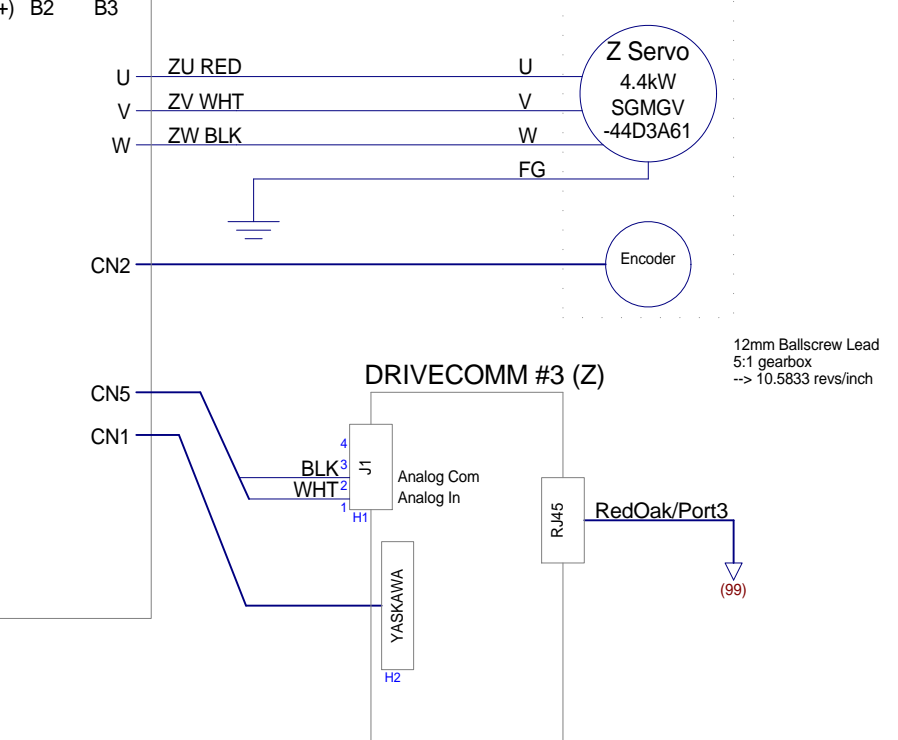
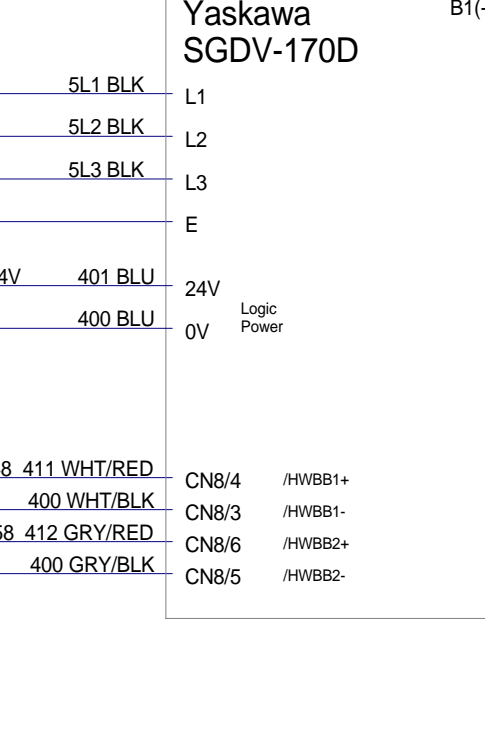

W Servo (SVW)

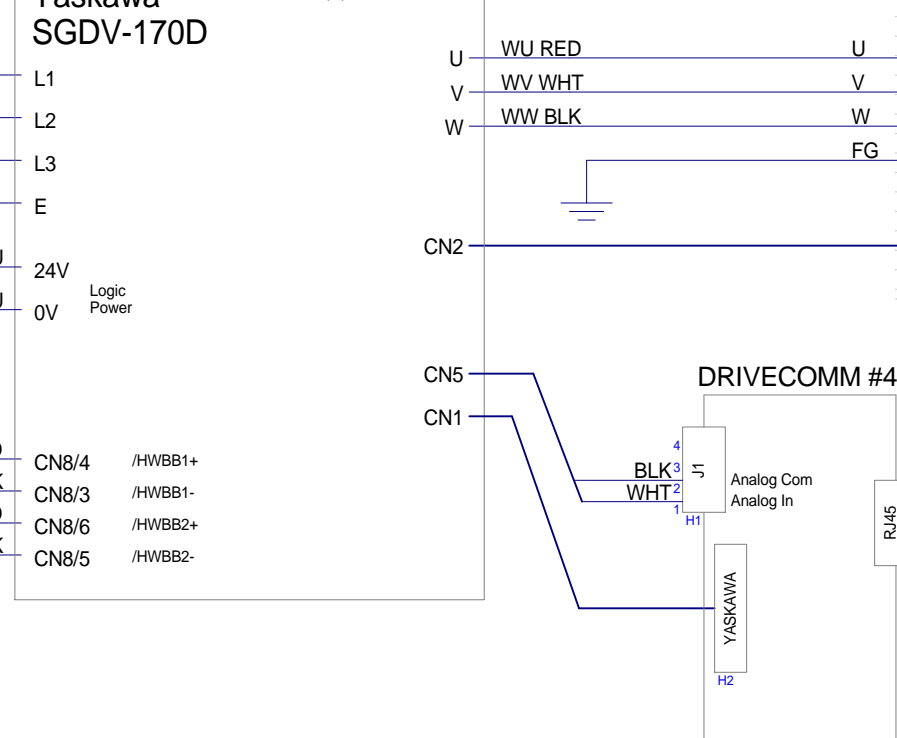
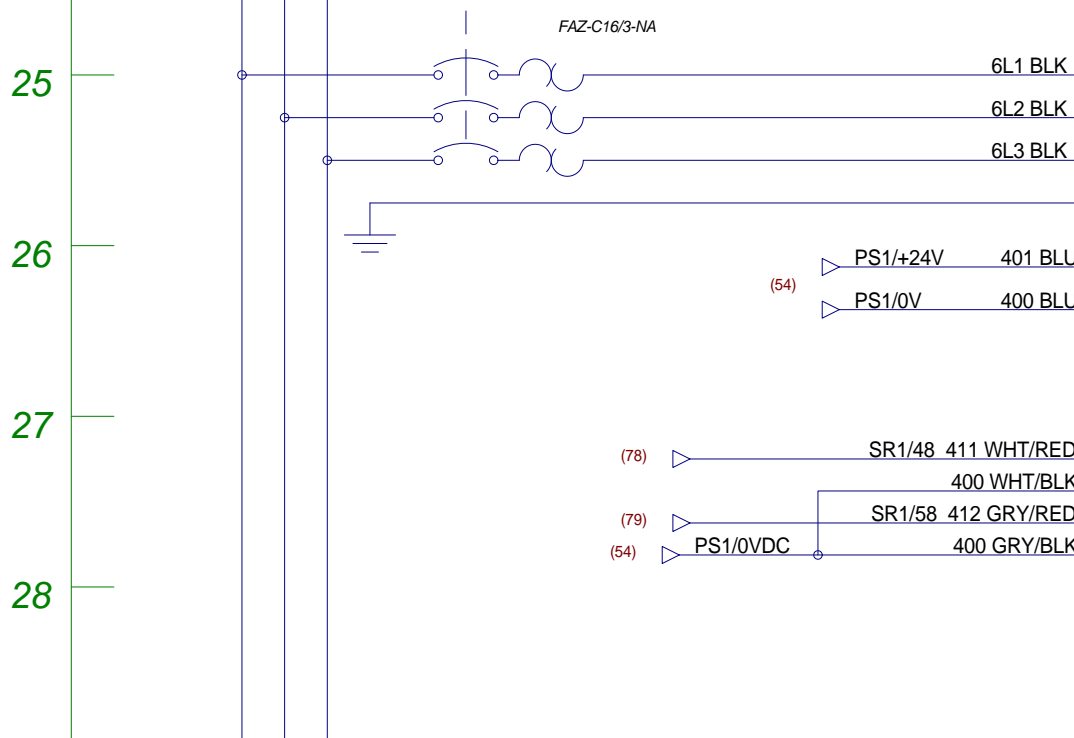

B Servo (SVB)

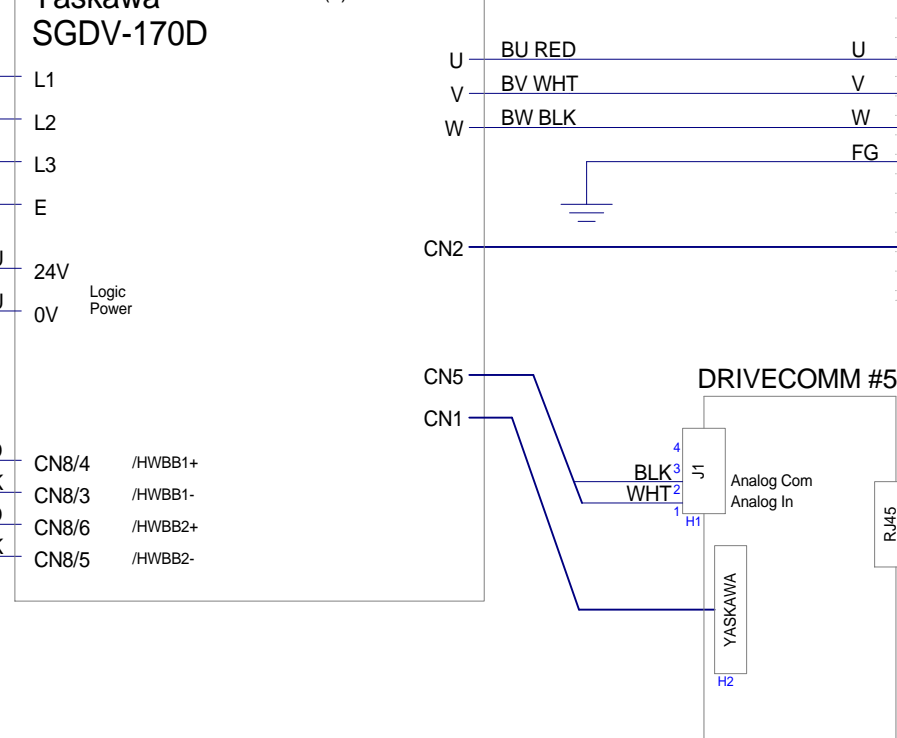
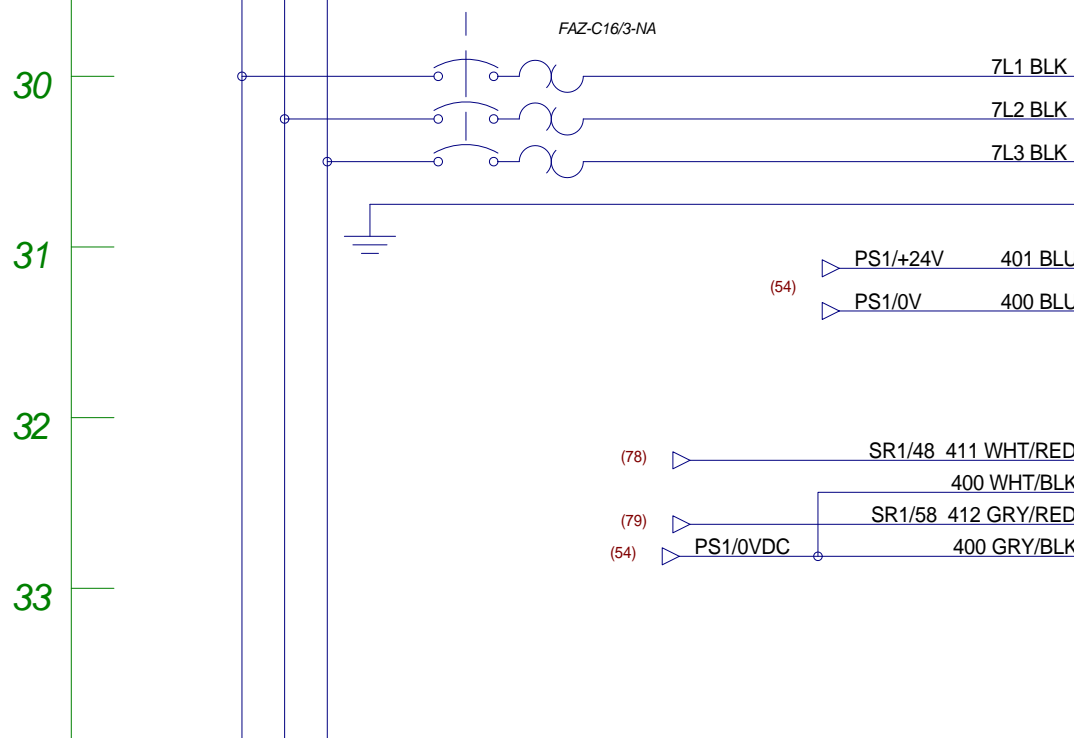

MTR2 Saddle Hydraulic Pump

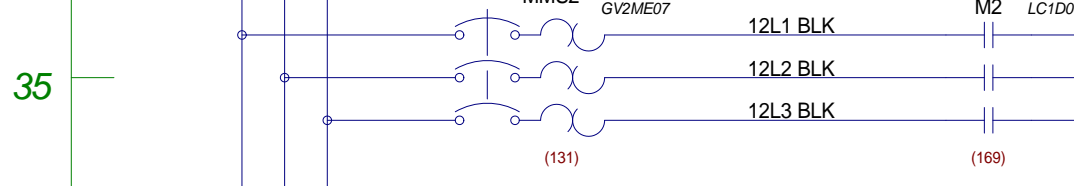

MTR3 Column Hydraulic Pump

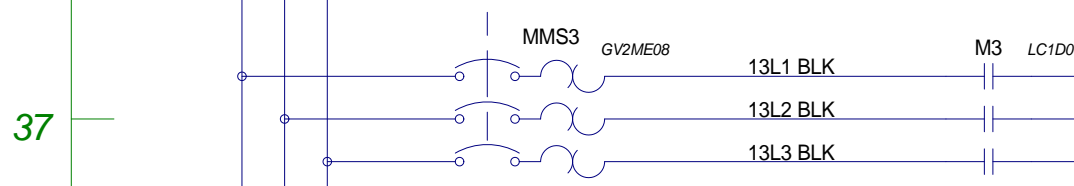

MTR4 X/B Axis Way Lube Pump

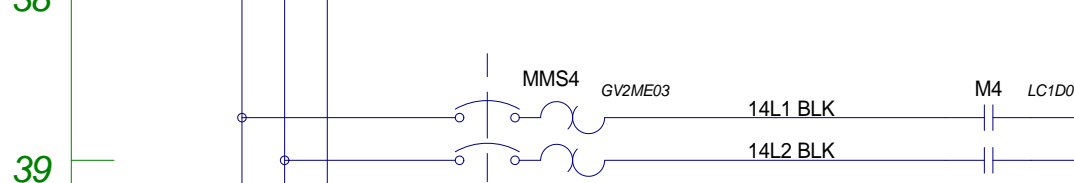

MTR5 Y Axis Way Lube Pump

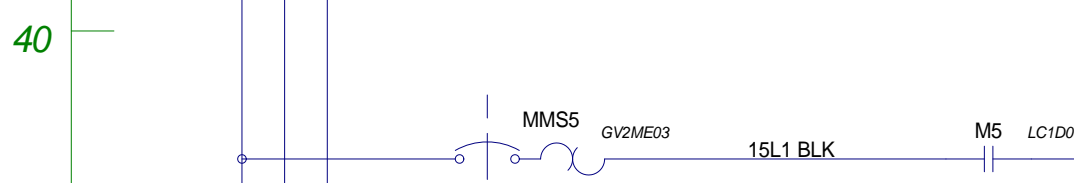

MTR6 W Axis Way Lube Pump

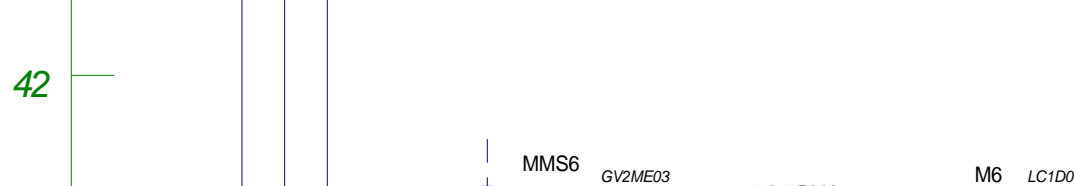

MTR7 Headstock Gear Lube Pump

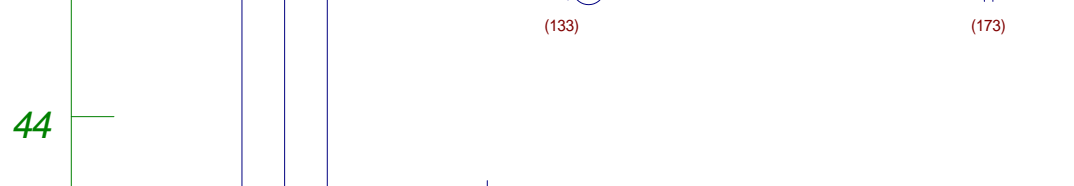

MTR8 Drawbolt Motor

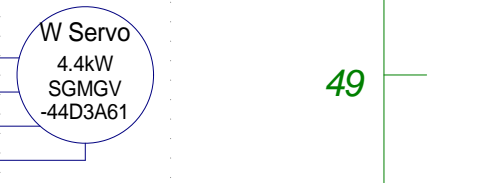

MTR9 Facing Head Traverse Motor

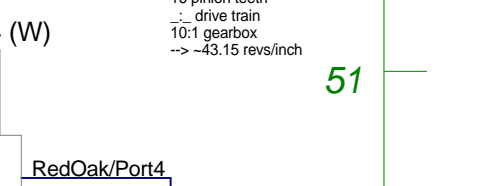

PS1 Power for Servo Drive Logic



PS2 Power for Y Brake Coils



T1 Transformer

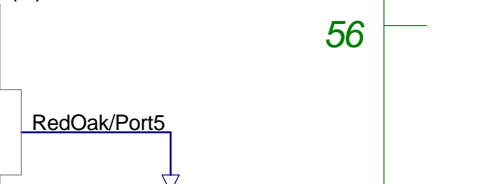

Cabinet Heat Exchanger



Spindle Motor Fan



CIRCUIT PROTECTION		MACHINE	
CB1	400VAC 100A 3-pole	Union BFT130 HBM w/ Centroid M400 Control	
CB2	400VAC 60A 3-pole	DRAWN BY	Marc Leonard
CB3 - CB7	400VAC 16A 3-pole	SIZE	D
CB8	400VAC 6A 3-pole	REV	1
CB9	400VAC 5A 2-pole	DATE	10-Jan-2020
CB10	400VAC 5A 2-pole	SCALE	none
CB11	220VAC 6A 3-pole	SHEET	1 OF 3
CB12	110VAC 10A 1-pole	FILE	K103512_1.VCD
Main Power Servo Drives 24VDC Power Supplies			
T1 Primary T2 Secondary, Air Conditioner			
PLC Outputs			