

360
361
362
363
364
365
366
367
368
369
370
371
372
373
374
375
376
377
378
379
380
381
382
383

PLCADD1616 #3 (Output Side)

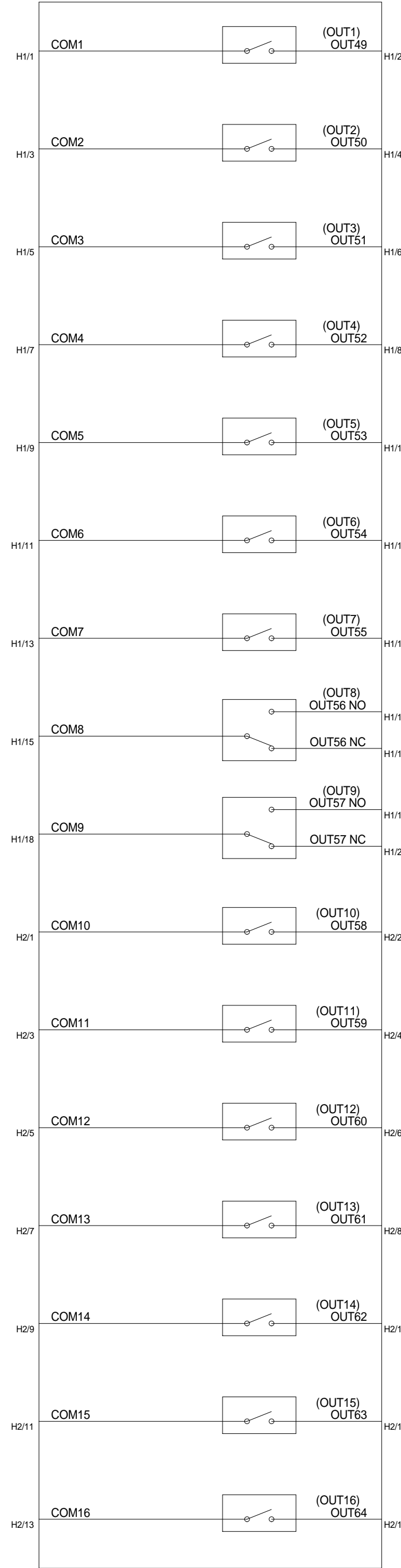

spare
spare
spare
spare
spare
spare
spare
spare
spare
spare
spare
spare
spare
spare
spare
spare

384
385
386
387
388
389
390
391
392
393
394
395
396
397
398
399
400
401
402
403
404
405
406
407

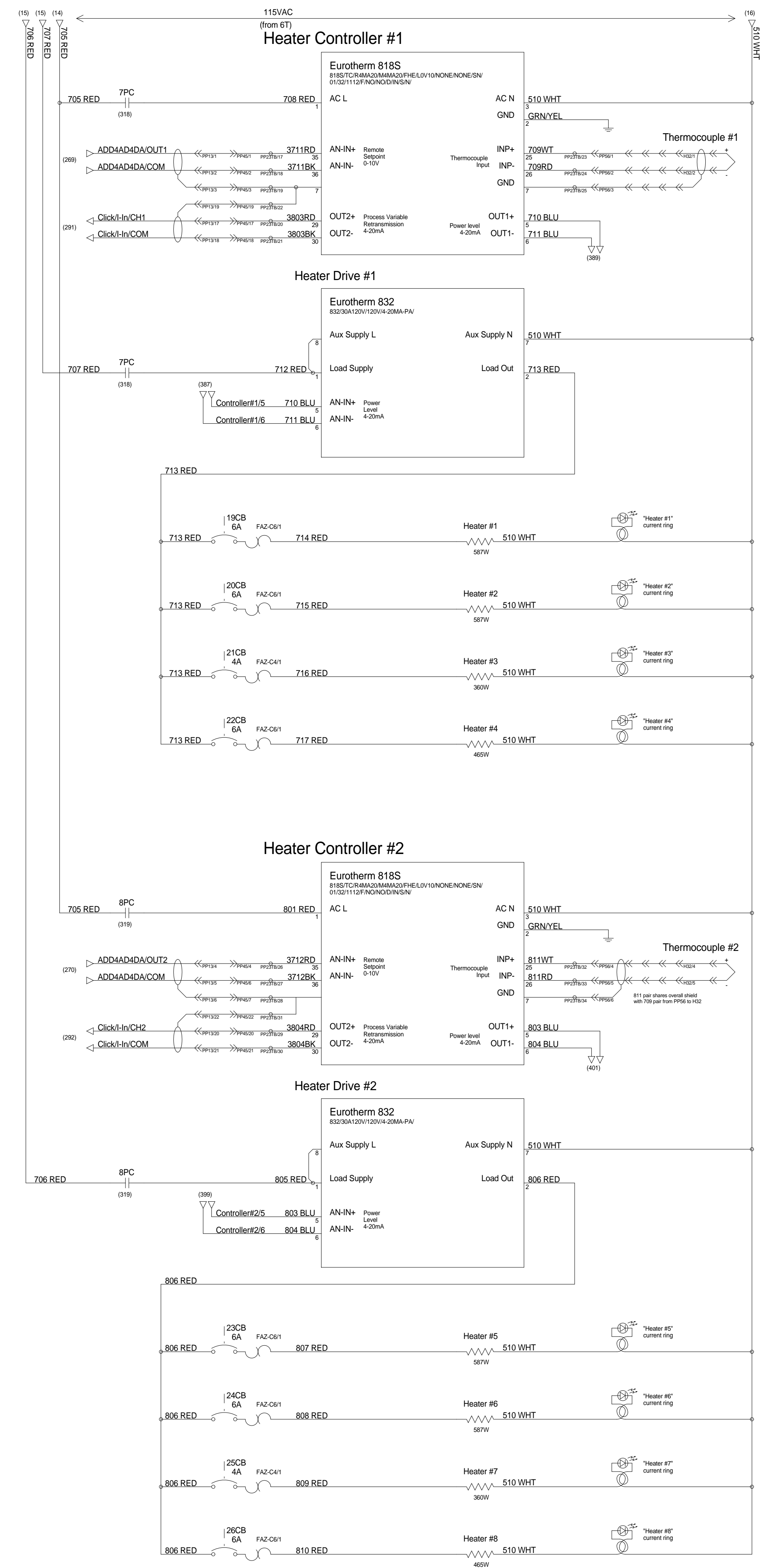

408
409
410
411
412
413
414
415
416
417
418
419
420
421
422
423
424
425
426
427
428
429
430
431

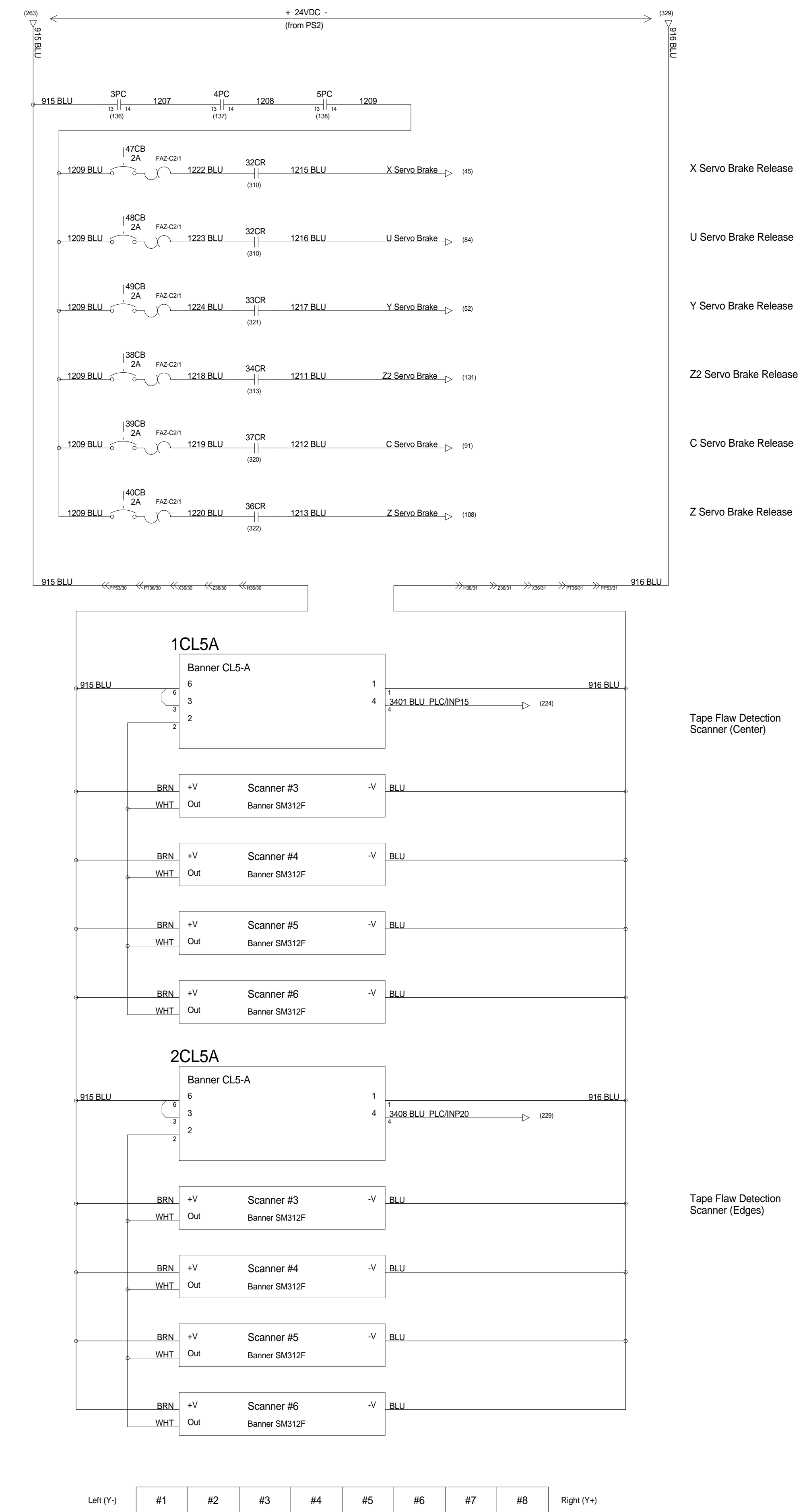

PART		
Cincinnati Flat Tape Layer with Centroid M400		
DRAWN BY	REV	DATE
Marc Leonard	1	28-May-2018
SCALE	SHEET	FILE
none	6 OF 7	K103003_6.VCD